

GRAB BARS

(POLISHED STAINLESS STEEL)
CONCEALED SNAP FLANGE

JOB #

QTY

REV. DATE

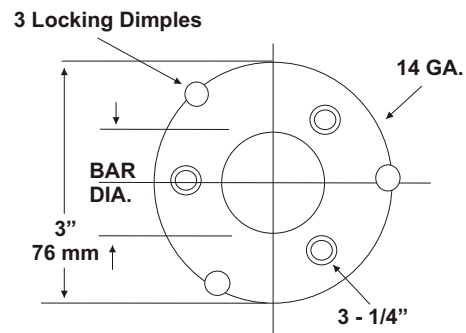
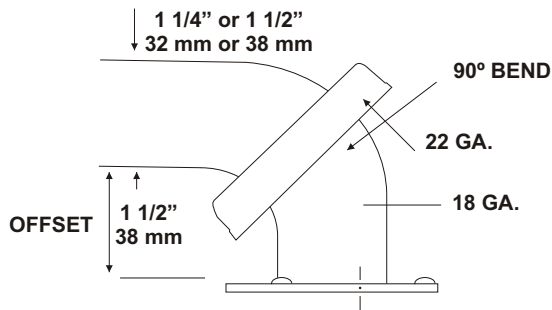

SPECIFICATIONS:

tubing: Fabricated of type 304 #18 ga stainless steel with a bright polished finish. Available in 1 1/4" and 1 1/2" outside diameter. All bends are formed by an automatic mandrel bending process. **All bars maintain a constant 1 1/2" offset.**

Flanges: Snap flanges are fabricated of 3" diameter, 3/8" deep drawn type 304 #22 ga stainless steel with a bright finish to match tubing. Flanges have dimples that secure over mounting plate.

Mounting Plates: Type 304 #14 ga stainless steel with three mounting point locations and heliarc welded to bar to form a one piece construction.

Strength: Bars with a projection no more than 5" off finished wall will sustain loads in excess of 900 lbs. When properly mounted. Bars with more than 5" projection will sustain a load of 250 lbs for 5 minutes when properly mounted.

Peened Surface: (Safety Grip, Anti-Slip) This area of the bar is only found on the gripping surface area.

Unit	Bar Diameter	Gripping Surface
UGPS2	1 1/4"(32mm)	Bright Finish
UGPS3	1 1/2"(38mm)	Bright Finish
UGPS2X	1 1/4 (32mm)	Peened Finish
UGPS3X	1 1/2"(38mm)	Peened Finish

**When measuring and ordering grab bars, remember bars are sized centerline to centerline.*

**Grab Bars comply with ADA Code 4.26.2*

**Non-chloric and non-abrasive cleaners should be used to clean surface of bars and flanges.*

INSTALLATION:

Before installing grab bars, verify with all state and local codes for requirements on bar diameter and type finish.

Recommended mounting heights for grab bars are 33" - 36" centerline above finished floor. All mounting of grab bars when possible should be in wall mounting back plates. Find centerline mounting points and place bar on line making sure to be on center. Transfer mounting points (3 per flange) to wall. Drill pilot holes and secure bar with proper anchors per application. Snap cover over mounting plate.

Do not use abrasive cleaners or cleaners with chloric solutions. Use a soft cloth to wipe down surface.

APPLICATION:

To provide a bright polished stainless steel concealed mount grab bar that is available in standard and custom configuration that comply's with ADA Code when installed properly.

