

GRAB BARS CONCEALED SNAP FLANGE

JOB #:

ITEM #:

QTY:

MOUNTING

HANDING

TYPE

SIZE A, B, C

OTHER

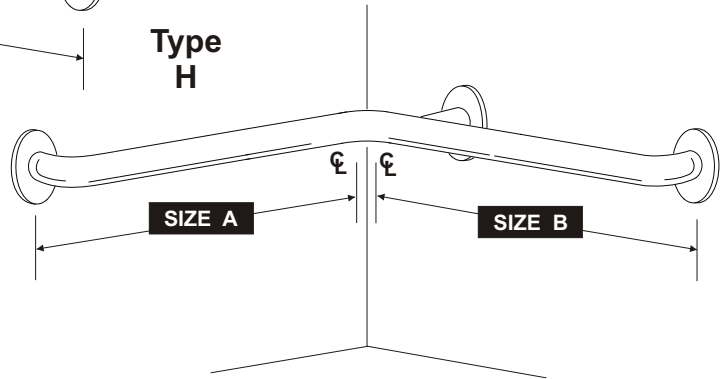
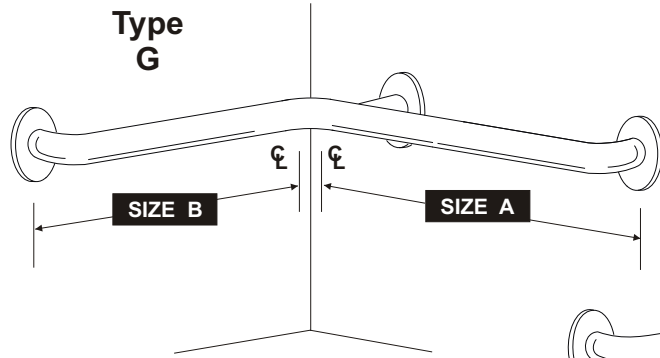

SPECIFICATIONS:

tubing: Fabricated of type 304 #18 ga stainless steel with a #4 satin finish. Available in 1", 1 1/4" and 1 1/2" outside diameter. All bends are formed by an automatic mandrel bending process. **All bars maintain a constant 1 1/2" offset.**

Flanges: Snap flanges are fabricated of 3" diameter, 3/8" deep drawn type 304 #22 ga stainless steel with #4 satin finish to match tubing. Flanges have dimples that secure over mounting plate.

Mounting Plates: Type 304 #14 ga stainless steel with three mounting point locations and heliarc welded to bar to form a one piece construction.

Strength: Bars that provide a 1 1/2" offset can support loads in excess of 900 lbs when properly installed. Other configurations can support loads in excess of 250 lbs when properly installed. Grab bars must be installed properly to support the loads intended.

Peened Surface: (Safety Grip, Non-Slip) This area of the bar is only found on the gripping surface area.

Unit	Bar Diameter	Surface
UG1	1" (25mm)	Satin Finish
UG2	1 1/4" (32mm)	Satin Finish
UG3	1 1/2" (38mm)	Satin Finish
UG1X	1" (25mm)	Peened Finish
UG2X	1 1/4" (32mm)	Peened Finish
UG3X	1 1/2" (38mm)	Peened Finish

*When measuring and ordering grab bars, remember bars are sized centerline to centerline.

*Grab Bars comply with ADA Code 4.26.2

*Non-chloric and non-abrasive cleaners should be used to clean surface of bars and flanges.

INSTALLATION:

Before installing grab bars, verify with all state and local codes for requirements on bar diameter and type finish.

Recommended mounting heights for grab bars are 33" - 36" centerline above finished floor. All mounting of grab bars when possible should be in wall mounting back plates. Find centerline mounting points and place bar on line making sure to be on center. Transfer mounting points (3 per flange) to wall. Drill pilot holes and secure bar with proper anchors per application. Snap cover over mounting plate.

FLANGE DIAGRAM

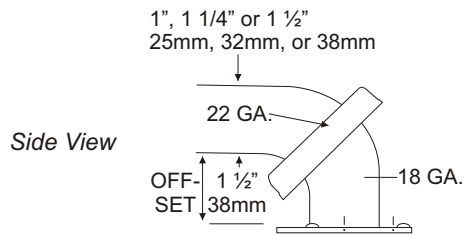
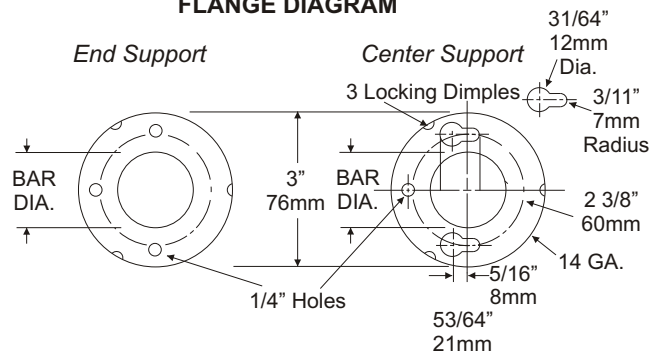

Form: GBSO_GH/2000