

MOUNTING HANDING TYPE SIZE OTHER

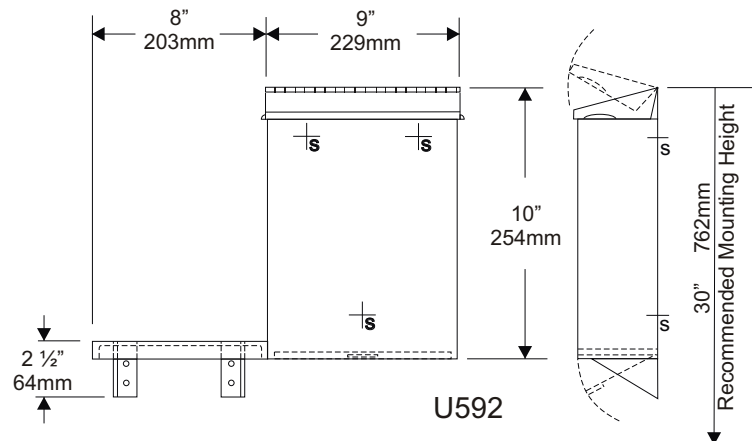
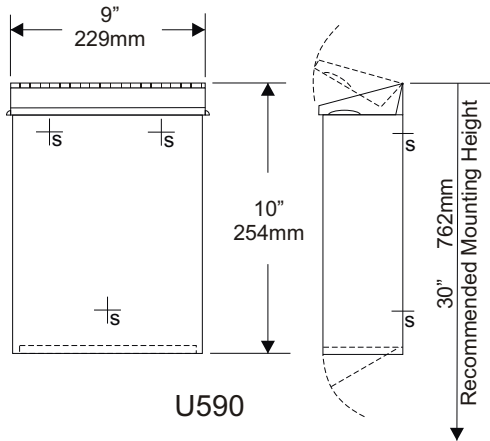
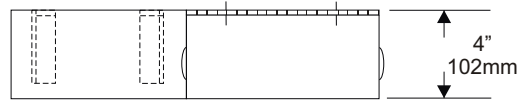
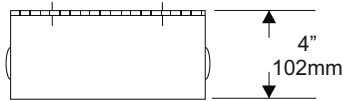

SPECIFICATIONS:

Cabinet Body: type 304 #22 ga stainless steel with #4 satin finish. Seamless construction with radius and hemmed edges.

Cabinet Back: Stainless steel welded to cabinet body with key hole mounting points.

Cover: Type 304 #22 ga stainless steel #4 satin finish with embossed handles on each side. NAPKIN DISPOSAL permanently embossed on sloped cover.

Bottom Panel: Type 304 #22 ga hinged and locked for removal of contents.

Hinges: Heavy duty, full length, stainless steel piano type hinges.

Lock: Commercial quality keyed like all other A & J cabinets.

U592 Shelf: Type 304 #22 ga stainless steel with 1/2" bends, hemmed and ground smooth. Shelf supported by two stainless steel brackets. Can be mounted on either side of disposal.

International Graphic Symbol (IGS) available on request.

U590: 9"W x 10"H x 4"D
229mm x 254mm x 102mm
Capacity: 1.6 gallons

U592: 17"W x 10"H x 4"D
431mm x 254mm x 102mm
Capacity: 1.6 gallons

INSTALLATION:

Provide an area at desired or specified location. Place unit on surface and transfer mounting points. Drill pilot holes and secure with proper fasteners. Install waxed liner.

If the U592 is being installed follow same steps then select side shelf is to be mounted and secure to surface.

APPLICATION:

To provide a surface mounted feminine napkin disposal that has bottom access panel to empty contents without coming in contact with the contents. Unit can be equipped with shelf.



Form: U590U592/2000