

**U730-1626
 MEDICINE CABINET**

JOB #:

ITEM #:

QTY:

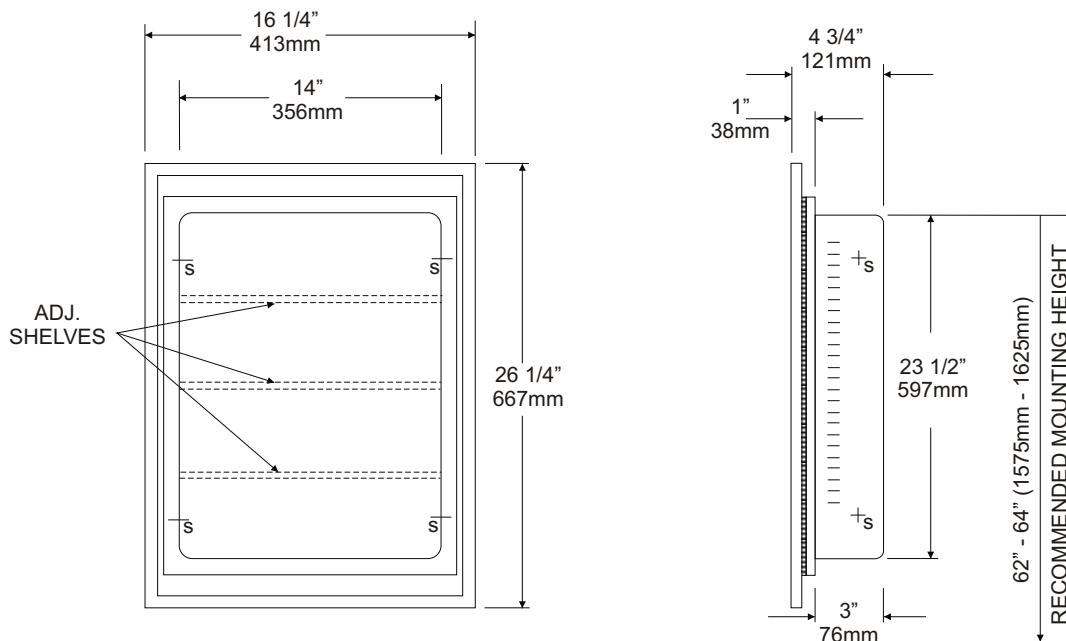

SPECIFICATIONS:

Body: Fabricated of one piece deep drawn steel construction, oven baked enamel finish. Integral louvers to accommodate adjustable shelves.

Mirror Door: 3/16" float plate glass, silver coated and sealed electrolytic copper plating. Door is secured by means of a magnetic catch.

Frame: Bright stainless steel finish.

Hinges: Heavy duty piano type hinges.

Shelving: steel construction to match cabinet body with 3/8" returns with all edges deburred to prevent injury.

U730-1626: Recessed Medicine Cabinet

Overall Size: 16 1/4"W x 26 1/4"H x 4 3/4"D

413mm x 667mm x 121mm

Wall Opening: 14"W x 24"H x 3"D

356mm x 610mm x 76mm

Shelving: 3 adjustable

U730-1626SM: Surface Mounted Medicine Cabinet

Overall Size: 16 1/4"W x 26 1/4"H x 4 3/4"D

413mm x 667mm x 121mm

INSTALLATION:

Coordinate installation with architect and or contractor. Provide wall opening 14"W x 24"H x 3"D that will allow cabinet to swing left or right without interference. Place cabinet in wall opening and secure with proper fasteners per application. Place unit on wall surface and make sure unit is level. Transfer mounting points and drill pilot holes. Secure unit to surface using proper fasteners per application.

To meet ADA code, a usable shelf on cabinet cannot be any higher than 44" (1120mm) above the finished floor. (4.2.4)

APPLICATION:

To provide a recessed or surface mounted white enamel steel medicine cabinet that has adjustable shelves.



Form: U730-1626/2000