

**U7311
 MEDICINE
 CABINET**

JOB #:

ITEM #:

QTY:

MOUNTING	HANDING	TYPE	SIZE	OTHER

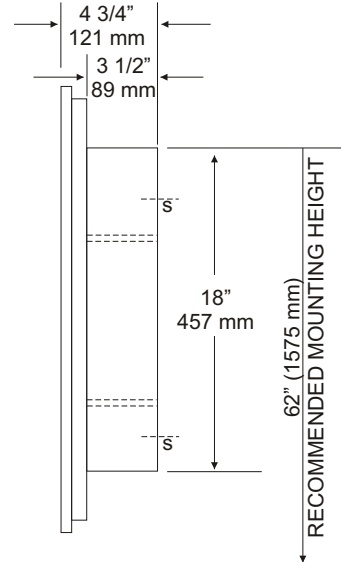
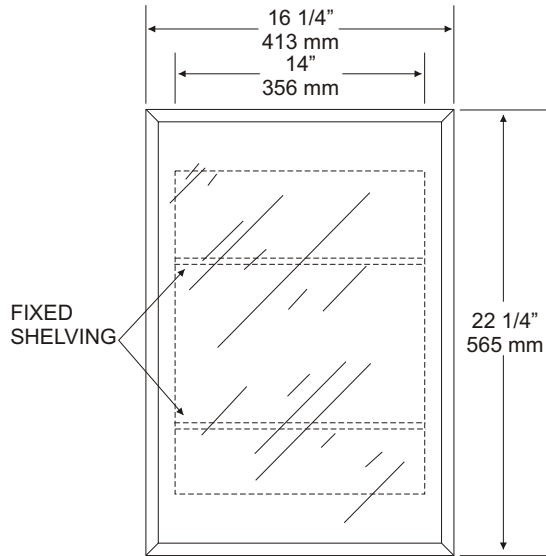

SPECIFICATIONS:

Cabinet Body: Fabricated of heavy duty, high impact polystyrene with a baked white finish that is rust resistant.
Mirror Door: Fabricated is fabricated of float plate glass, silver coated and sealed with an electrolytic copper plating. Door is kept closed by means of a magnetic catch and secured to body with pin hinges.
Mirror Frame: Fabricated of bright polished steel channel.
Shelving: Equipped with 2 fixed shelves.

U7311: Recessed Medicine Cabinet

Overall Size: 16 1/4"W x 22 1/4"h x 4 3/4"D
 413mm x 565mm x 121mm

Wall Opening: 14"W x 18"H x 3 1/2"D
 356mm x 457mm x 89mm

INSTALLATION:

Coordinate with contractor or architect to avoid interference with pipes, vents, etc. Provide a wall opening 14"W x 18"H x 3 1/2"D. Place unit in opening and make sure unit is level before securing with proper fasteners.

APPLICATION:

To provide a recessed medicine cabinet with fixed shelves.

